



WILLE 865



The Wille 865 is really a multi-functional wheel loader, whose work attachments can also be connected to the rear lift or to the top of the engine compartment. The most powerful operating hydraulic system on the market with two hydraulic circuits, and a load-sensing variable displacement pump is a standard feature. The combined flow of the motor hydraulics is 200 lpm, which is particularly needed when driving a snow blower under tough conditions. Wille is low, agile and able to work smoothly even in narrow places.

Wille machines are equipped with the new more effective Kohler KDI 100 kW engine (EU Off Road Stage 4). Automatic EcoDrive (AED) reduces RPM in transfer speed and saves fuel and lowers emission app. 25 %. The machines never lack power even during tough transport driving or when ploughing heavy snow. The lifting forces are equivalent to those of a wheel loader of the same size. Its transfer speed is max. 50 kph which can be limited if necessary.



ENGINE

- Kohler KDI 3404 TCR-SCR EU Off Road Stage 4
- 4-cylinder turbo-charged Diesel-engine with intercooler DOC and SCR
- Common Rail – fuel system
- Displacement 3359 cm³
- Output 100 kW (136 hv)/ 2200 rpm
- Max. torque 500 Nm/1400 rpm
- Fuel tank 100 l
- AdBlue tank 16 l

ELECTRIC SYSTEM

- Voltage 12 V
- Battery 145 Ah
- Start motor 3,2 kW
- Alternator 120 A

TRANSMISSION

- Hydrostatic transmission
- Variable displacement pump
- Variable displacement motor
- Driving direction to the front and rear is changed electrically
- 2-speed electro-hydraulic range gearbox
- Driving speed/traction force 0–20 kph 4,720 daN
0–50 kph 2,330 daN

NOISE LEVEL

- External under LwA 102 dBA
- Inside cabin under LpA 70 dBA

WEIGHT (KG)

- Own weight 7050/7550
- Front axle weight 2790
- Rear axle weight 4260/4760*
- * Rear tyres with liquid filling

STEERING SYSTEM

- Hydrostatic articulated steering
- Turning angle +/- 39°
- Angle of oscillation +/- 12.5°

AXLES

- Automatic friction locks in the front and rear
- Hydraulically assisted multi-disc brakes in oil-bath in the front and rear
- Electro-hydraulic control of the parking brake with immobilizer

OPERATING HYDRAULICS

- Load-sensing variable displacement pump 145 lpm, 220 bar
- Gear pump 55 lpm, 220 bar
- Max. flow of motor hydraulic pumps 200 lpm, 220 bar
- Volume of the hydraulic system about 150 l
- Hydraulic oil cooler

LOADER

- Optional quick-coupler types: Kunta 500 and Volvo BM
- Hydraulic quick-coupler for work attachment
- Hydraulic self-level feature of the loader
- Automatic suspension for the loader, 5–10 kph
- Hydraulic pilot control
- Service support for loader-arms
- Loader-arm support for levelling work

TYRES

- 460/65R24 (width of the machine 2070 mm)
- 500/60R22.5 (width of the machine 2150 mm)

STANDARD EQUIPMENT

- Motor hydraulic pumps
- double-acting to the front 0–145 lpm
- single-acting to the front 55 lpm
- single-acting to the front 55–200 lpm
- single-acting to the rear 55/0–145 lpm
- Hydraulic circuit for 3rd cylinder, proportional control 0–90 lpm
- Hydraulic circuit for 4th cylinder, proportional control 0–90 lpm
- Double-acting cylinder hydraulics to the rear
- Electric inching and accelerator pedal
- Socket outlet of 12 V in the front and rear
- From the cabin foldable Beacon light shaft
- TFT display
- Radio/mp3 Bluetooth/AUX-in/USB/SD-Card
- Windscreen and rear window wiper and washer
- Rear mirrors with heating
- Low beam automation
- LED work lights in the front, EMC- and E-certified
- Adjustment of steering wheel tilt
- Seat with heating
- 2-point safety belt
- Roof window
- Safety cabin ROPS (ISO 3471)
- Safety cabin FOPS (ISO 3449 1365 J)
- Engine heater
- Bottom armours in the front and rear
- Towing hitch
- Reverse alarm, on/off selectable
- Electric automatic main switch
- Brackets for work attachments on top of the engine compartment

OPTIONAL EQUIPMENT

- Hydraulic rear lift with towing hitch (Kunta 500)
- Lifting force to the upper position 34 kN
- Thrust force with rear blade 17.7 kN
- Float position
- Hydraulic circuit for 5th cylinder
- Hydraulic circuit for 6th cylinder
- Heater for hydraulic oil tank
- Central pressure lubrication
- Air-conditioning, automatic
- Air-cushioned seat, 3-point seat belt
- Readiness for cabin heater
- Brake valve for trailer
- Elevated cabin 160 mm
- FOPS roof (ISO 3449 11600 J)
- Counter-weight 400 kg
- Joystick control
- Rear view camera
- Backup camera
- Refill pump for hydraulic oil

Wille Optim

work attachments

- Rotary brush 240, 270, 320
- Collecting sweeper 650
- Soil bucket 1,300 l
- Snow bucket 2500 l
- Multi-function bucket 2,000 l
- Leave bucket 1,900 l
- Hydraulic rear blade 2,500
- Rear sand spreader 700 l
- High-pressure washer 1,500 l
- Platform with hydraulic tipping 800 l
- Access platform Wille-9
- Forklift forks



	FRONT FACE OF THE QUICK-COUPLER	BUCKET 1300 L	FORKLIFT FORK 500 mm LOAD CENTRE DISTANCE
Hydraulic lifting force at lower position, kN	65,8	61,4	51,6
Hydraulic lifting force at upper position, kN	42,5	39,6	33,3
Rated transport capacity, kg		1,970* 2,190**	2,440 (on even surface*) 2,664 (on even surface**)
Tipping load, with straight/turned machine, kg	5,000/4,330* 5,495/4,760**	4,570/3,940* 5,065/3,380**	3,560/3,050* 3,960/3,330**
Break-out force of the bucket, kN		42,5	

Dimensions with 1,300 l bucket:

Width 2,150 mm

Inner turn radius 2,650 mm

Outer turn radius 4,800 mm

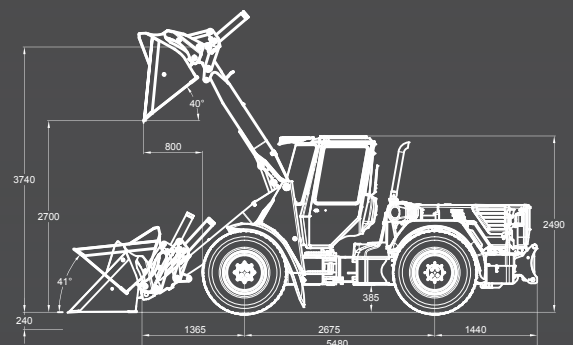

* with Nokia 460/65 R 24 tyres and rear-lift. According to ISO 8313 and EN 474-3 standards

** with rear-lift and rear tyres with liquid filling