

Wille 475 Δ

- Your year-round machine



Compact power

- Wille handles every season

The Wille 475Δ is the most popular multi-function machine in its size class and the most controllable such product on the market. The driver is at the centre of the design and there are plenty of technical features. Even though the 475Δ is a compact size, it has features usually found only in larger machines.

Features that improve work efficiency and ergonomics make the Delta Series an intelligent co-worker. Work is safer and more meaningful when you can focus on observing the environment and important work tasks: The Smart Flow feature automatically adjusts the output of the engine hydraulics in accordance with the machine's speed. For example, when sanding roads machine's automation keeps the amount of grit even.

Wille 475 Δ is an agile and strong work machine for versatile work tasks.

- **Easy-to-use controls**
- **Agile and versatile work machine**
- **SmartFlow intelligent central lubrication system (optional)**



MOTOR

- Kohler KDI 2504 TCR, EU Off Road Stage 5
- 4-Cylinder turbocharged and inter-cooled diesel engine
- DOC and PDF
- Common Rail fuel system
- Engine displacement 2482 cm³
- Power 55.4 kW (74.3 hv)/2300 rpm
- Max torque 300 Nm/1500 rpm
- Fuel tank 50 l

ELECTRICAL SYSTEM

- Voltage 12 V
- Electric main power switch
- Battery 105 Ah
- Starter motor 2.0 kW
- Charger 100 A

TRANSMISSION

- Hydrostatic, electronically controlled
- Variable displacement pump
- Variable displacement engine
- Electric direction change forwards and backwards
- 1-speed reduction gear
- Driving speed 0 to 40 km/h
- Pulling power 1600 daN

NOISE LEVELS

- External: below LwA 101 dBA ISO 6395:2008
- Inside the cab: below Lpa 69db ISO 6396:2008

WEIGHT

- Total 3550 kg
- Front axle weight 1640 kg
- Rear axle weight 1910 kg

STEERING SYSTEM

- Hydrostatic frame steering
- Turn angle +/- 40°
- Tilt angle +/- 9°

AXLES

- Automatic friction locks in the front
- Hydraulically aided oil bath multi-disc brakes on the front
- Automatic parking brake

WORK HYDRAULICS

- Load-detecting variable displacement pump 80 l/min, 200 bar
- Gear pump 50 l/min, 200 bar
- Engine hydraulics maximum output 130 l/min, 200 bar
- Hydraulic system capacity ca. 70 l
- Hydraulic oil cooler

LOADER

- Quick coupler options: Kunta 500, Vila and Trima
- Hydraulic work device quick locking
- Hydraulic stabiliser
- Automatic loader suspension 4 to 10 km/h
- Electric pre-steering
- Arm maintenance support
- Arm support for pushing

TYRES

- 305/70R16 (machine width 1640 mm)
- 380/60R15 grass tyres (machine width 1830 mm)

STANDARD EQUIPMENT

- Engine hydraulics (max output 2300 rpm)
- Two-way front 0-80 l/min
- Two-way front 50 l/min
- One-way front 50-130 l/min
- One-way rear 50/0-80/50-130 l/min
- 3:s cylinder hydraulics, propo controlled
- 4:s cylinder hydraulics, propo controlled
- Dual-acting cylinder hydraulics rear
- Electric crawler and gas pedal
- 12 V socket front and rear
- Lowerable LED warning beacon
- 7" display
- Radio/USB/iPod/mp3/wma/Bluetooth
- Rear windscreen wiper and washer
- Heated rear-view mirrors
- Automatic headlights
- LED work lights in front and EMC and E approved in rear
- Height and depth-adjustable steering wheel
- Heated seat
- 2-point seatbelt
- Additional rear lights in upper corners of cab
- Programmable work device and driver profiles
- 4 different driving modes to choose from
- Smart Cruiser cruise control
- Safety cab ROPS (ISO 3471)
- Safety cab FOPS (ISO 3449 1365 J)
- Engine heater
- Bottom plates front and rear
- Pull point
- Reverse buzzer that can be turned off
- Attachment lugs for work devices above the engine compartment

OPTIONAL EXTRAS

- Back tilter: Kunta 500, Vila and Trima
- Back tilter float position
- Hydraulic oil heater
- Smart Lube central lubrication
- Automatic air conditioning
- Air-cushioned seat with 3-point seatbelt
- Internal heater ready
- Storage box for cab
- Reverse camera
- 2 + 2 LED auxiliary work lights
- 8 pcs LED warning lights
- 4 pcs LED waist beacons
- Trailer brake valve
- Multifaster
- Special colour
- Immobiliser
- Eberspächer fuel heater
- Start immobiliser
- Cup holder
- Roller blind
- Accessory bar
- Heated windscreen

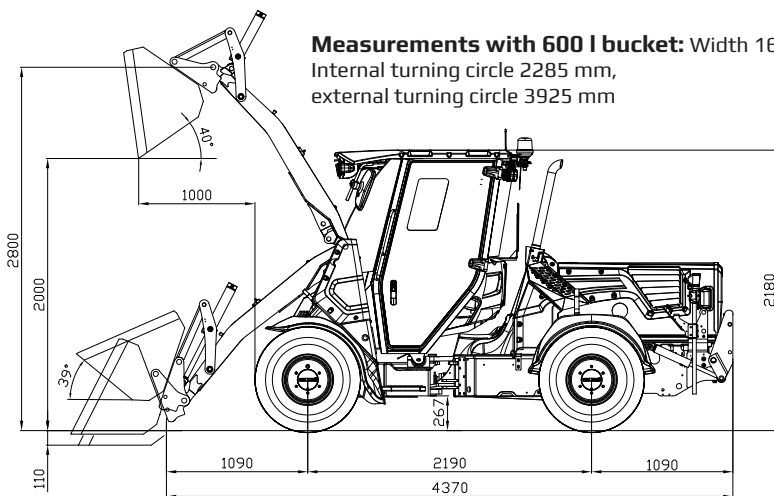

Measurements with 600 l bucket: Width 1640 mm, Internal turning circle 2285 mm, external turning circle 3925 mm

	QUICK COUPLER PLATE FRONT	BUCKET 600 L	FORKLIFT FORK with 500 mm distance of COG
Hydraulic lifting power lower position, kN	24,7	23,0	19,0
Hydraulic lifting power upper position, kN	11,6	10,3	9,5
Nominal transport capacity, kg		1005*	1090* (on even surface)
Tipping load with straight/turned machine kg	2530/2270*	2170/2010*	1700/1370*
Bucket braking force, kN		16,4	

*With back tilter and without counterweight. Tipping loads measured in accordance with standard ISO 14397.

