



# WILLE 475Δ

COMPACT POWER

[www.willemachines.com](http://www.willemachines.com)

LRQA  
CERTIFIED

ISO 9001 · ISO 14001

# WILLE 475Δ

# COMPACT POWER

**The Wille 475Δ is the most popular multi-function machine in its size class and the most controllable such product on the market. The driver is at the centre of the design and there are plenty of technical features. Even though the 475Δ is a compact size, it has features usually found only in larger machines.**

Thanks to its articulated frame steering and compact size, the 475Δ is nimble when driven. The cab of the machine sits on the front frame, making the machine low, and the cab can follow the work device. Work devices can be mounted on the loader, on top of the bonnet or on the back tilter, which makes it possible to perform several jobs at once. Thanks to its versatile work devices, the machine can be used all year round. Unlike with wheel loaders, the excellent weight distribution of Wille holds the machine steady even when using the back tilter. The 40 km/h top speed is also the highest in the size range.

One of the most important technical innovations is the electrically controlled loader valve and drive transmission.

The driver can adjust the movement speed of the loader according to their preference, and can save values for different work devices. The new, precise cruise control makes working easy and reliable.

### Completely new cab

The cab of the Wille 475Δ is completely new and significantly roomier than for previous models. Thanks to the glass door and arching windscreen, visibility is excellent, both to the ground and up to the maximum height of the arms.

The low dashboard improves visibility to the work device and frees up knee space for the driver. Thanks to the steering wheel, which can be adjusted both depth- and height-wise, every driver can easily find an ergonomic driving position. The comfort of the cab is completed by its silence and long list of optional extras.

The new user interface makes work easier for the driver. The easy-to-use interface is operated using a scroll wheel and shortcut keys, which have been positioned with-

in reach of the driver's right hand and are there to make work easier and more efficient. There are 30 programmable work device and driver profiles available, which allow for correct and cost-efficient operation of the work device.

The user interface also includes safety features, such as warnings about incorrect use, user instructions for the driver and maintenance reminders. The safety and visibility of the machine can be maximised with the eight warning beacons and the four waist beacons available as optional extras.

Thanks to the electronically controlled loader, the driver can adjust the functions of the work device and hydraulics. The driver can programme the joystick operations according to their preferences and create work profiles for different work devices.

In addition, the machine has adjustable bucket shake.

WILLE IS ALSO AVAILABLE  
IN TRACTOR VERSION



As an option, the Wille 475Δ is also available with EU tractor type approval.

Contact our sales personnel for more information!



# FIRST-CLASS TECHNOLOGY

The Wille 475Δ has a stage V emission class, 55kW Kohler diesel engine equipped with particle filter and catalytic converter. The fuel used can be 100% HVO biodiesel, which significantly decreases the carbon footprint.

**AUTOMATIC ECO DRIVE**

The machine comes as standard with the Automatic Eco Drive feature, which reduces fuel consumption and noise. It lowers engine speed automatically as needed, saving fuel and reducing emissions.

**SMART DRIVE**

Käyttöprofiilit

Nostopiikit

Smart Drive is a more ergonomic alternative to a creeping pedal. It uses software to convert the accelerator into a drive pedal: you can use the hand throttle to set the engine speed and only use the pedal to adjust the driving speed.

**SMART CRUISER**

000031 h

The precise Smart Cruiser cruise control optimised for work use operates using logic similar to a car's cruise control. It makes, for example, ploughing and brushing work easier and makes changing work locations more comfortable.

**SMART FLOW**

The Smart Flow feature adjusts the output of the motor hydraulics automatically based on machine speed. For example, it keeps the dispensing rate even regardless of varying driving speed during gritting.

**SMART LUBE**

With the Smart Lube system, which is available as an option, the driver can select the lubrication output of the central lubrication system from four preset settings. Selecting the correct supply rate prevents excessive lubrication.

In Soft Drive mode, the gas pedal of the Wille operates more precisely, which makes the Wille more stable and easier to control for tasks requiring precision. Soft Drive mode is ideal for using forklift lifting forks, for example.



## ACCESSORIES 475Δ

- 1. Back tilter
- 2. Storage box
- 3. Cup holder
- 4. Reverse camera
- 5. Special colour
- 6. Multifaster
- 7. LED warning lights

Additional options include: air conditioning, immobiliser, air-cushioned seat, LED work lights and LED additional work lights.



# WILLE 475Δ

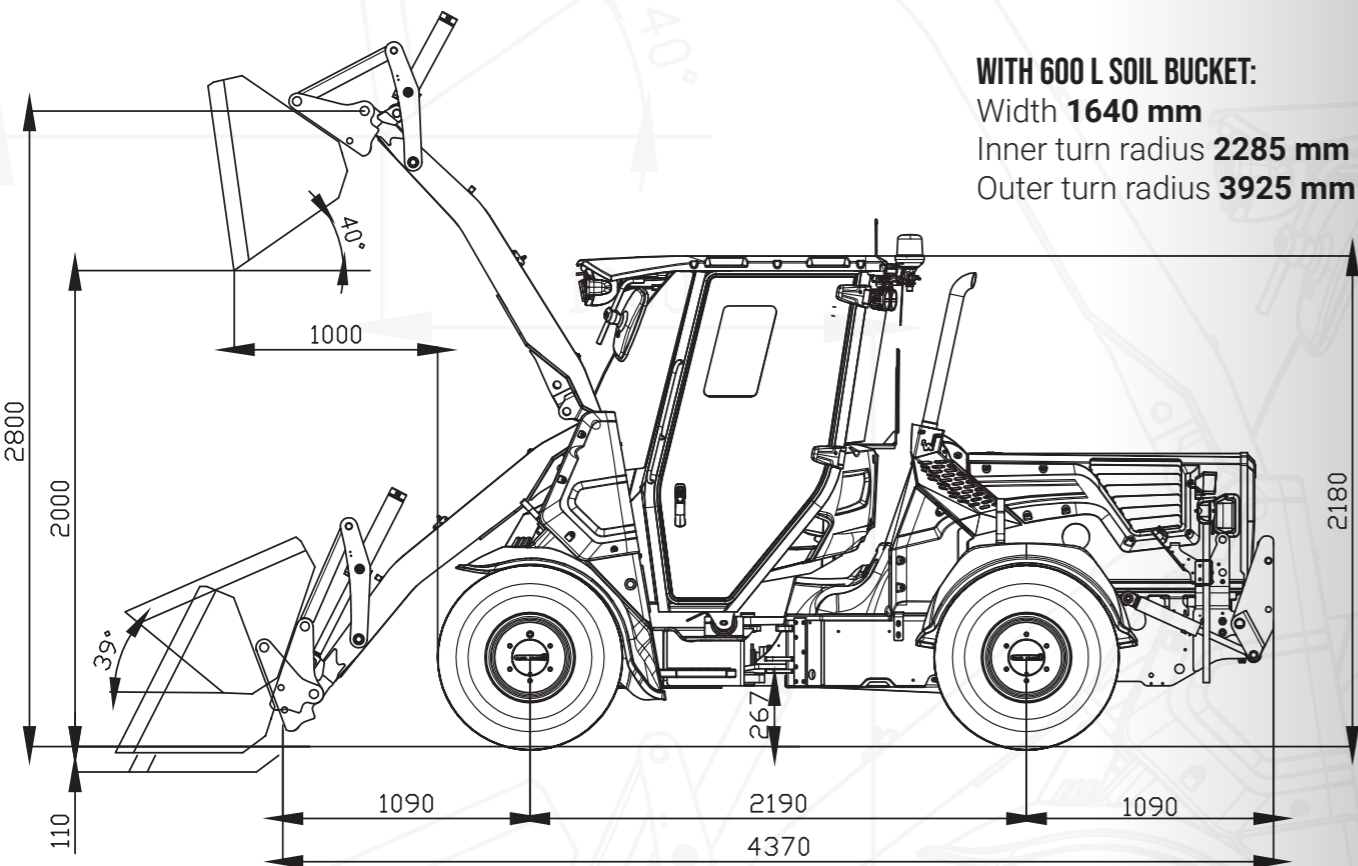

**WITH 600 L SOIL BUCKET:**  
 Width **1640 mm**  
 Inner turn radius **2285 mm**  
 Outer turn radius **3925 mm**

## ENGINE

- Kohler KDI 2504 TCR, EU Off Road Stage 5
- 4 cylinder turbo charged and intercooled diesel engine
- DOC and DPF
- Common Rail fuel system
- Engine displacement 2482 cm<sup>3</sup>
- Output 55,4 kW (74,3 hv)/2300 rpm
- Max. torque 300 Nm/1500 rpm
- Fuel tank 50 l

## ELECTRIC SYSTEM

- Voltage 12 V
- Electric main switch
- Battery 105 Ah
- Starter motor 2,0 kW
- Charger 100 A

## TRANSMISSION

- Hydrostatic, electronically controlled
  - Variable displacement pump
  - Variable displacement engine
- Electric direction change forwards and backwards

- 1-speed reduction gear
- Driving speed/tractive force 0-40 km/h/1600 daN

## NOISE LEVELS

- Outside cabin under L<sub>WA</sub> 101 dBA (ISO 6395:2008)
- Inside cabin under L<sub>pa</sub> 69 dBA (ISO 6396:2008)

## WEIGHTS

- Total 3550 kg
- Front axle weight 1640 kg
- Rear axle weight 1910 kg

## STEERING SYSTEM

- Hydrostatic articulated frame steering
- Turn angle +/- 40°
- Tilt angle +/- 9°

## AXLES

- Automatic friction locks in the front
- Hydraulically assisted multi-disc brakes in oil-bath in the front
- Automatic parking brake

## WORK HYDRAULICS

- Load-detecting variable displacement pump 80 l/min, 200 bar
- Gear pump 50 l/min, 200 bar
- Engine hydraulics maximum output 130 l/min, 200 bar
- Hydraulic system capacity ca. 70 l
- Hydraulic oil cooler

## FRONT LOADER

- Quick coupler options: Kunta 500, Vila and Trima
- Hydraulic work device quick locking
- Hydraulic stabiliser
- Automatic loader suspension 4-10 km/h
- Electric pre-steering
- Arm maintenance support
- Arm support for bulldozing

## TYRES

- 305/70R16 (machine width 1640 mm)
- 380/60R15 grass tyres (machine width 1830 mm)

## STANDARD EQUIPMENT

- Engine hydraulics (max output 2300 rpm)
  - two-way front 0-80 l/min
  - one-way front 50 l/min
  - one-way front 50-130 l/min
  - one-way rear 50/0-80/50-130 l/min
- 3rd cylinder hydraulics, propo controlled
- 4rd cylinder hydraulics, propo controlled
- Dual-acting cylinder hydraulics rear
- Electric inching and accelerator pedal
- Speed adjusted motor hydraulics
- Socket outlet of 12 V in the front and the rear
- Lowerable LED warning beacon
- 7" display
- Radio/Bluetooth/AUX-in/USB
- Windscreen and rear window wiper and washer
- Heated rear-view mirrors
- Automatic headlights
- LED work lights in the front and the rear
- Height and depth-adjustable steering wheel
- Heated seat
- 2-point seatbelt
- Additional rear lights in upper corners of cab
- Programmable work device and driver profiles
- 4 different driving modes: Eco, Eco Off, Soft Drive and Smart Drive
- Smart Cruiser cruise control
- Safety cabin ROPS (ISO 3471)

- Safety cabin FOPS (ISO 3449 1365 J)
- Engine heater
- Bottom plates in the front and the rear
- Tow hitch
- Reverse alarm (can be connected on/off by operator)
- Brackets for work attachments on top of the engine compartment

## OPTIONAL EQUIPMENT

- Back tilter: Kunta 500, Vila and Trima
- Back tilter float position
- Hydraulic oil heater
- Smart Lube central lubrication
- Automatic air conditioning
- Air-cushioned seat with 3-point seatbelt
- Internal heater ready
- Storage box for cab
- Rear view camera
- 2 + 2 LED additional work lights
- 8 pcs LED warning lights
- 4 pcs LED waist beacons
- Trailer brake valve
- Multifaster
- Special colour
- Immobiliser
- Eberspächer fuel heater
- Anti-Theft System
- Roller blind
- Accessory bar
- Cup holder
- Heated windscreen

## WILLE OPTIM WORK ATTACHMENTS

- Rotary brush 200
- Collecting sweeper 305
- Ice-plough
- Soil bucket 600 l
- Snow bucket 1200 l
- High-tipping bucket 800 l
- Multi-function bucket 1000 l
- Leaf bucket 1200 l
- Hydraulic rear blade 1800
- Rear sand spreader 370 l
- Disc spreader 700 l
- Leaf collector 1000 l
- High-pressure washer 1000 l
- Platform 270 l
- Hydraulic platform 300 l
- Access platform Wille 9

	Front face of the quick coupler	Soil bucket 600 L	Forklift fork with 500 mm distance to center of gravity
Hydraulic lifting force, bottom position kN	24,7	23,0	19,5
Hydraulic lifting force, top position kN	11,6	10,3	9,5
Rated transport capacity kg		1005*	1090* (even surface)
Tipping load with straight/turned machine kg	2530/2270*	2170/2010*	1700/1370*
Break-out force of the bucket kN		16,4	

\*With back tilter and without counterweight. Tipping loads measured in accordance with standard ISO 14397.

# 10 REASONS TO CHOOSE WILLE

1. Efficient year-round operation
2. Quiet, spacious and ergonomic cab
3. 4 different driving modes to choose from: Eco, Eco off, Soft and Smart
4. Versatile and powerful hydraulics
5. Clear and intuitive user interface
6. Modifiable to suit every application and driver
7. Easy maintenance
8. Multi-function Smart Cruiser cruise control
9. Functions to assist the driver
10. Appearance can be modified to match your branding

We reserve the right to errors and technical changes.

**READ MORE:**  
[WWW.WILLEMACHINES.COM](http://WWW.WILLEMACHINES.COM)

# WILLE

## WILLE DEALERS NEAR YOU:

>> [www.willemachines.com](http://www.willemachines.com)

