



WILLE

ETS

SMART LINK

SMART CRUISER

SMART DRIVE

SMART FLOW

SMART LUBE



[www.willemachines.com](http://www.willemachines.com)

PERFORMANCE BEYOND ITS SIZE



**The brand new Wille 275 Delta is the latest addition to the Wille Delta product family. This powerful machine designed for around-the-year use fits into tight spaces with ease and is packed full of new features to make your work easier.**

Thanks to its low frame, the 275 Delta can fit into tight spaces and machine has excellent agility. The new frame structure is ideal for larger work attachments as well. Thanks to its low centre of gravity, the 275 Delta remains stable even on inclined surfaces, making it an excellent choice for cutting grass on gentle slopes, for example. The short front and rear overhangs make the 275 Delta easy to handle. The 275 Delta's wheelbase, which is slightly longer than that of the previous 275 model, stabilizes travel between locations and enables higher driving speeds.

The cabin has been completely redesigned with a focus on driving ergonomics and is extremely roomy for its size. Naturally, an air-cushioned seat, air conditioning and other familiar conveniences are available for the cabin. The user interface of the Wille 275 Delta has also been entirely revamped, and it is now easier than ever to monitor and control machine functions via the display.

The Wille 275 Delta is equipped with all the familiar features of the Delta series, such as customer-branded cover plating, Delta series smart features and the handrest control wheel which is found in larger machines and used to control the machine's user interface and functionalities.

In addition to familiar smart features, the Wille 275 Delta comes standard with the completely new Wille Smart Link fleet monitoring service, which allows you to keep track of your machine and monitor its status with ease.



## PERFORMANCE BEYOND ITS SIZE

- ▶ **Versatile, high-performance hydraulics for a wide range of work attachments.**
- ▶ **Optional hydromechanical PTO, which enables front-mounted attachments that require mechanical power take-off.**
- ▶ **42 kW (56 hp) engine for exceptional performance for the machine size.**

# WILLE SMART LINK



Wille Smart Link is a fleet management service designed for Wille environmental care machines, which allows you to easily monitor the status of the machine and plan work ahead. The information available to the driver is also available to other users with the help of a web browser-based interface.

## USING WILLE SMART LINK YOU CAN:

- ▶ Track the movements and location of the fleet in real time
- ▶ Monitor the efficiency, economy or historical data of machine use
- ▶ Saves reports on machine performance key figures (KPI)
- ▶ Anticipate and plan downtimes related to machine maintenance and service

Along with the browser-based user interface, Wille Smart Link enables the open transfer of data produced by the machine through the interface also to possible external information systems already in use by customers. With the help of Wille Smart Link, the owner of the machine gets more and more accurate data about the work of the Wille environmental care machines, than with traditional retrofit monitoring devices.

## MORE COMPREHENSIVE AND ACCURATE DATA:

- ▶ About working
- ▶ Efficiency
- ▶ About the state and condition of the machine
- ▶ About consumption and emissions

With the help of Wille Smart Link, the machine's maintenance network can also analyze the need for machine maintenance in problematic situations, as well as analyze possible problem points remotely, which shortens the service response time, which helps to minimize service interruptions caused by unexpected problems.

Wille Smart Link will be offered as a standard feature in all Wille models from the beginning of 2024. Its use is free for the duration of the machine's valid warranty, after which the owner of the machine can voluntarily continue using the system as an additional paid service.



# SMARTER THAN EVER

In addition to Wille Smart Link, the Wille 275 Delta has other smart features familiar from previous Delta series machines that make the driver's work easier.



The precise Smart Cruiser cruise control optimised for work use operates using logic similar to a car's cruise control. It makes, for example, ploughing and brushing work easier and makes changing work locations more comfortable.



Smart Drive is a more ergonomic alternative to a creeping pedal. It uses software to convert the accelerator into a drive pedal: you can use the hand throttle to set the engine speed and only use the pedal to adjust the driving speed.



The Smart Flow feature adjusts the output of the motor hydraulics automatically based on machine speed. For example, it keeps the dispensing rate even regardless of varying driving speed during grit-ting.



With the Smart Lube system, which is available as an option, the driver can select the lubrication output of the central lubrication system from four preset settings. Selecting the correct supply rate prevents excessive lubrication.

# W53

PERFORMANCE BEYOND ITS SIZE

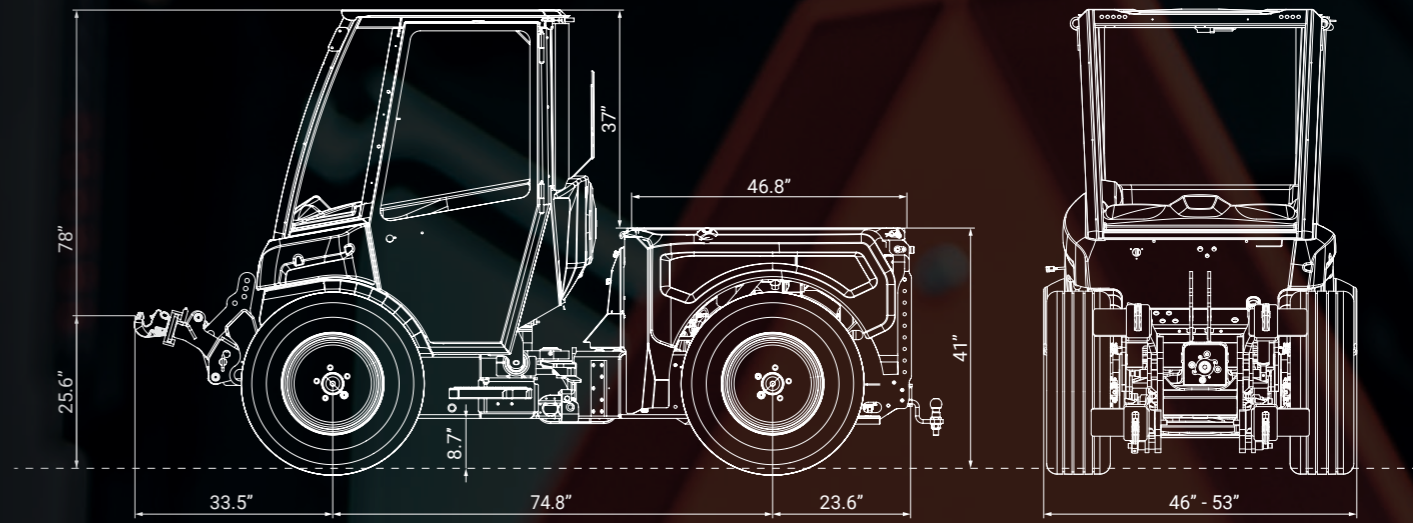

▶ Width **46" / 53"** ▶ Height **78"** ▶ Length **132"** ▶ Weight **4800 lbs**

## ENGINE

- ▶ Kohler KDI 1903TCR EPA
- ▶ 3 cylinder turbo charged and intercooled diesel engine
- ▶ DOC and DPF
- ▶ Common Rail fuel system
- ▶ Engine displacement 1861 cc
- ▶ Output 42 kW (56 hp)/2600 rpm
- ▶ Max. torque 166 ft-lbs/1500 rpm
- ▶ Fuel tank 13.2 gal

## ELECTRIC SYSTEM

- ▶ Voltage 12 V
- ▶ Electric main switch
- ▶ Battery 85 Ah
- ▶ Starter motor 2,2 kW
- ▶ Charger 100 A

## TRANSMISSION

- ▶ Hydrostatic, electronically controlled
  - Variable displacement pump
  - 2-speed wheel motors
- ▶ Four wheel drive
- ▶ Electric direction change forwards and backwards
- ▶ Two (electrohydraulically controlled) speed ranges
- ▶ Driving speed
  - 0-12.5 mph
  - 0-25 mph
- ▶ Joystick activated hydraulic differential lock
- ▶ Hydraulically assisted multi-disc brakes in oil-bath in the front
- ▶ Automatic parking brake

## WEIGHTS

- ▶ Own weight 4800 lbs
- ▶ Front axle weight 2200 lbs
- ▶ Rear axle weight 2600 lbs

## STEERING SYSTEM

- ▶ Hydrostatic articulated frame steering
- ▶ Turn angle +/- 45°
- ▶ Tilt angle +/- 7.5°

## WORK HYDRAULICS

- ▶ Gear pump 14.5 gpm
- ▶ Gear pump 9.3 gpm
- ▶ Gear pump 5.3 gpm
- ▶ Max motorhydraulic flow 29 gpm
- ▶ Max pressure of the hydraulic system 2900 psi
- ▶ Volume of hydraulic system approx. 16 USgal
- ▶ Hydraulic oil cooler

## FRONT HITCH

- ▶ 3 point Cat 1
- ▶ Lifting arms mechanical float
- ▶ Automatic suspension 2.5-6 mph
- ▶ Float position
- ▶ Hydraulic pilot control
- ▶ Lifting force
  - Lower position 2900 lbs
  - Upper position 2700 lbs
- ▶ Lifting height 25.6"

## TIRES

- ▶ 265/70R16 (width of the machine 53")
- ▶ 205/80R16 (width of the machine 46")

## STANDARD EQUIPMENT

- ▶ Electric inching and accelerator pedal
- ▶ Speed adjusted motor hydraulics (Smart Flow)
- ▶ 4.3" screen
- ▶ Radio/Bluetooth/AUX-in/USB
- ▶ Windscreen and rear window wiper and washer
- ▶ Heated rear-view mirrors
- ▶ LED work lights in the front and the rear
- ▶ Height adjustable steering wheel
- ▶ Heated seat
- ▶ 2-point seatbelt
- ▶ Additional rear lights in upper corners of cab
- ▶ 3 different driving modes: Transport, Heavy Duty, Smart Drive
- ▶ Smart Cruiser cruise control
- ▶ Bottom plates in the front and the rear
- ▶ Tow hitch
- ▶ Reverse alarm (can be connected on/off by operator)
- ▶ Brackets for work attachments on top of the engine compartment

## OPTIONAL EQUIPMENT

- ▶ Hydraulic adjustment of lifting arms
- ▶ Hydromechanical PTO
- ▶ 5th cylinder hydraulics front
- ▶ Hydraulic oil heater
- ▶ Smart Lube central lubrication
- ▶ Joint stabilizer
- ▶ Extra dual-acting rear cylinder hydraulics
- ▶ Hydraulic tiltable platform
- ▶ Manual air conditioning
- ▶ Air-cushioned seat with 3-point seatbelt
- ▶ LED headlights
- ▶ 2 + 2 LED additional work lights
- ▶ 8 pcs LED warning lights
- ▶ Special colour
- ▶ Accessory bar

## WILLE OPTIM WORK ATTACHMENTS

- ▶ Several different work equipment available, **ask your Wille salesperson for more!**

# 10 REASONS TO CHOOSE



- ▶ Efficient year-round operation
- ▶ Quiet, spacious and ergonomic cab
- ▶ 3 different driving modes to choose from: Transport, Heavy Duty, Smart Drive
- ▶ Versatile and powerful hydraulics
- ▶ Clear and intuitive user interface
- ▶ Modifiable to suit every application and driver
- ▶ Easy maintenance
- ▶ Multi-function Smart Cruiser cruise control
- ▶ Functions to assist the driver
- ▶ Appearance can be modified to match your branding

We reserve the right to errors and technical changes.



Read more [www.willemachines.com](http://www.willemachines.com)



Wille dealers near you:

# WWW.WILLEMACHINES.COM